

OBSERVATION TOWER

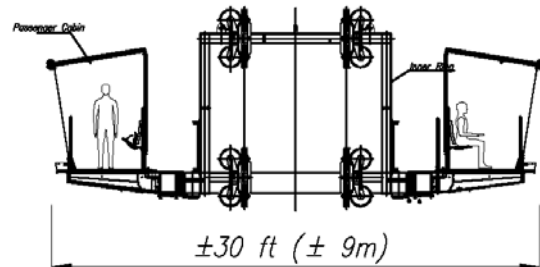

CHANCE MORGAN

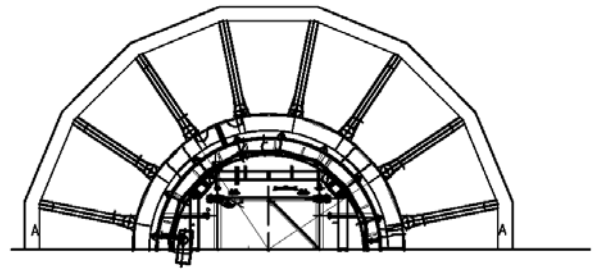
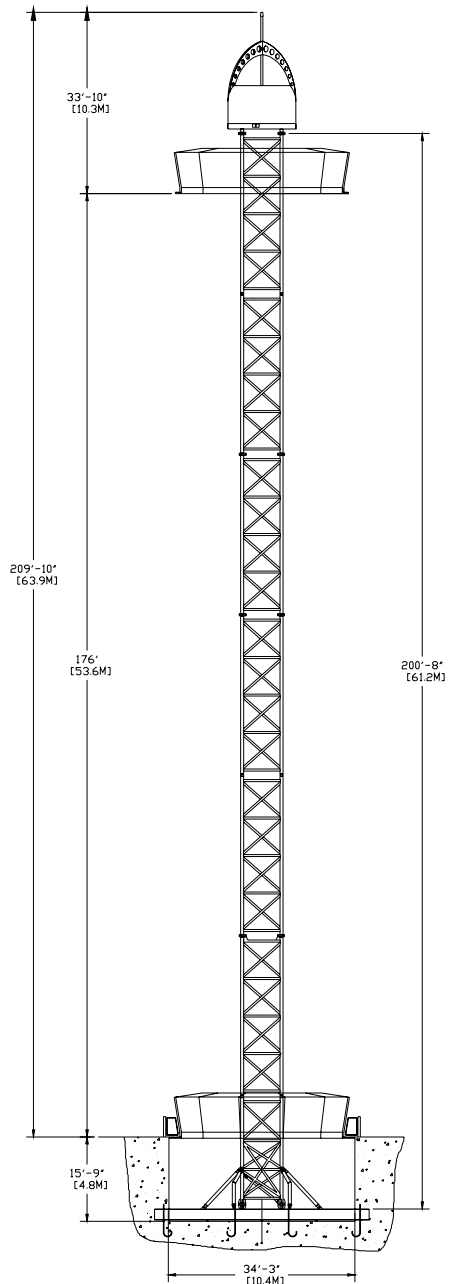

CROSS SECTION GONDOLA

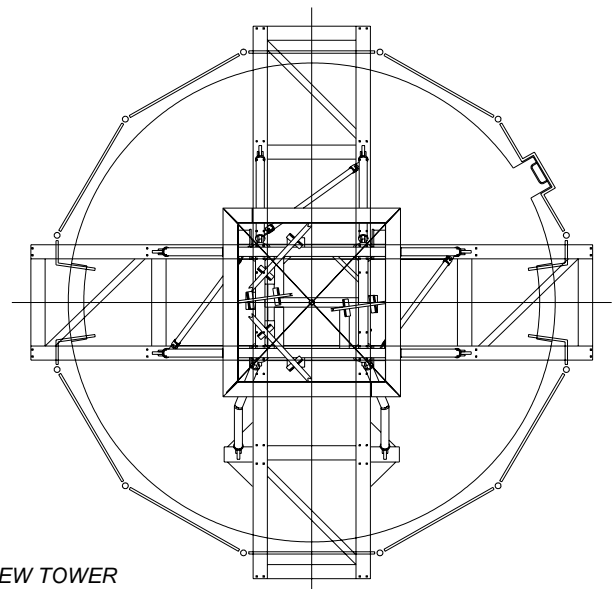

TOP VIEW TOWER

- **Tower Height:** 200.6'
- **Total Height:** 209.8'
- **Gondola Diameter:** Approx. 30'
- **Gondola Capacity:** 32 persons
- **Gondola Speed:** 1 m/s
(lifting/lowering)
- **Gondola Speed:** 1 rpm
(revolutions)
- **Highest Gondola Position:** 176'
- **Max. Load:** 5,440 lbs.
(32 persons @ 170 lbs.)
- **Pit Width:** 34.3' diameter
- **Pit Depth:** 15.8'

Designed by Ronald Bussink